



BEVERAGE-AIR

| | |
|-----------------|------|
| Project: _____ | AIA# |
| Item: _____ | |
| Location: _____ | SIS# |
| Approved: _____ | |

STF49HC DUAL ACCESS, FORCED AIR: SCHOOL MILK SERIES

SCHOOL MILK FORCED AIR COOLER

STF49HC Dual Access Cooler
Hydrocarbon Series

MODEL:
STF49HC-1-S

5 Year Parts/Labor Warranty Available
7 Year Compressor Warranty



CABINET CONSTRUCTION

- Stainless steel exterior and interior
- Stainless steel lids, hinged doors and door latches
- Full electronic control
- Dual sided access
- Heavy-duty epoxy coated steel wire floor racks standard
- Floor drain is centrally located for easy cleaning and connecting to drain hose with hose adapter
- Flexible compression door gaskets, ensures a tight seal
- Self-latching doors/lids with safety bumpers
- Exterior thermometer
- Cylinder locks
- 5" Heavy-duty plate casters (2 with locks)
- Balanced, forced-air refrigeration system provides rapid chilling of product

OPTIONS & ACCESSORIES

- 3 Year parts/labor standard, additional 2 year warranty available
- Corner bumpers
- Cafeteria tray slides
- Graphics

REFRIGERATION SYSTEM

- Uses environmentally friendly, energy efficient R290 refrigerant, and meets all regulatory requirements for CARB, SNAP, DOE & more
- Maintains product temperature between 36°F- 40°F



Please verify qualifying units by visiting:
www.energystar.gov/cfs



3779 Champion Blvd., Winston-Salem, NC 27105
1-888-845-9800 Fax: 1-336-245-6453
Beverage-Air.com Sales@bevair.com



BEVERAGE-AIR

School Milk Cooler - Dual Access Model: STF49HC-1-S

| MODEL | STF49HC-1-S |
|----------------------------------|-------------|
| EXTERNAL DIMENSIONAL DATA | |
| Width Overall | 49" |
| Depth Overall | 34" |
| Height Overall with Casters | 47 3/4" |
| Number of Lids/Doors | Dual Access |
| Both Lids Extended | 64" |
| INTERNAL DIMENSIONAL DATA | |
| NET Capacity (cubic ft.) | 20.55 |
| Internal Width Overall (in) | 46" |
| Internal Depth Overall (in) | 30" |
| Internal Height Overall (in) | 24 5/8" |
| CASE CAPACITY | |
| 13" X 13" X 11" | 12 |
| 19" X 13" X 11" | 8 |
| ELECTRICAL DATA | |
| Full Load Amperes | 2.46 |
| REFRIGERATION DATA | |
| Horsepower | 1/4 |
| Capacity (BTU/Hr) | 1851 |
| Heat Rejection (BTU/Hr) | 2776.5 |
| Charge (lbs/grams) | 0.154/70 |
| SHIPPING DATA | |
| Gross Weight - Crated | 334 lbs |
| Height - Crated | 55" |
| Width - Crated | 54" |
| Depth - Crated | 38" |

Model Views

Required Clearance: 4 3/8" bottom

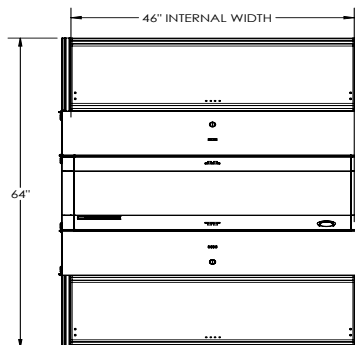

PLAN VIEW

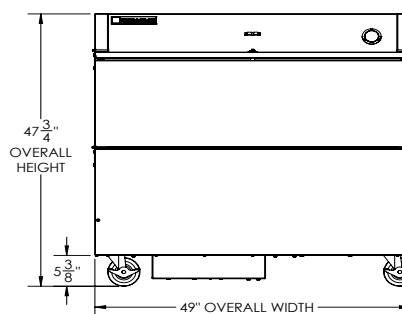

ELEVATION VIEW

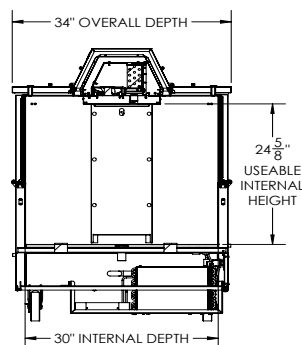

SIDE VIEW

ELECTRICAL CONNECTION



115/60/1
NEMA 5-15P

Unit pre-wired at factory
and include 8' long cord
and plug set.

